

THIS IS A TWO PAGE PARTS LIST.
THIS FIRST PAGE APPLIES TO
MODELS 45-0485-01 & L5-0485-01
AT REVISION B AND LATER REVISIONS.

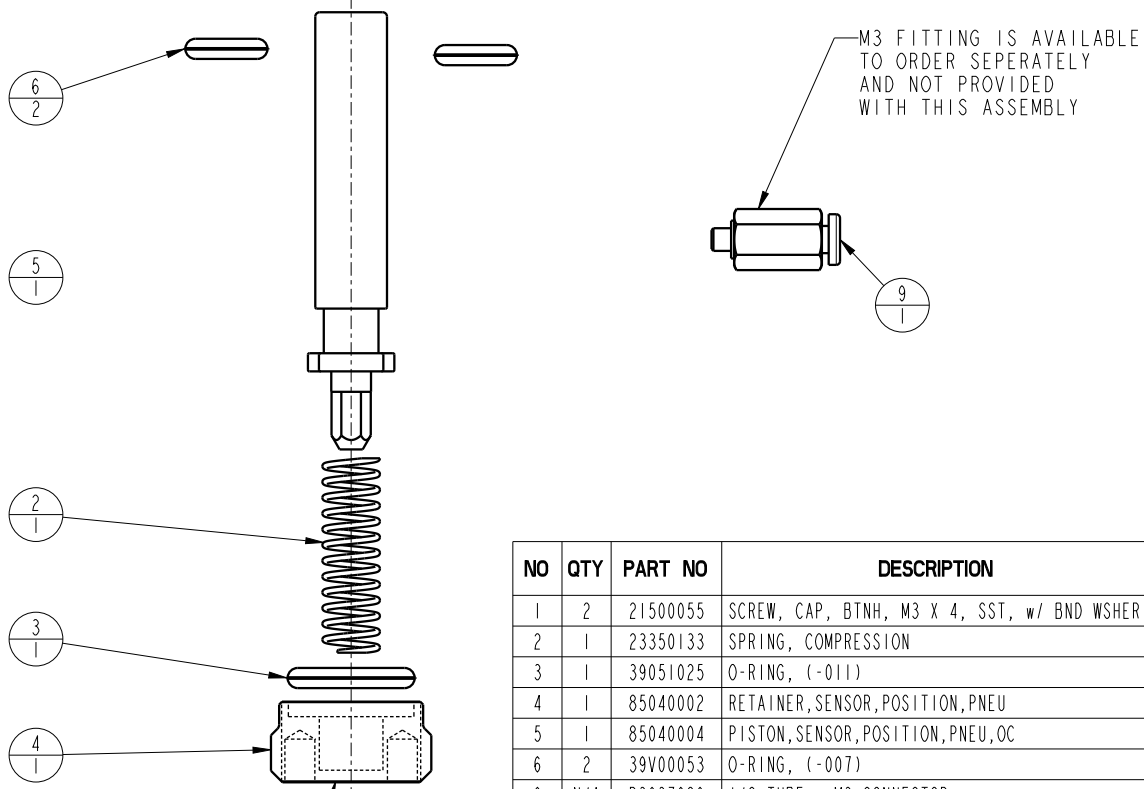
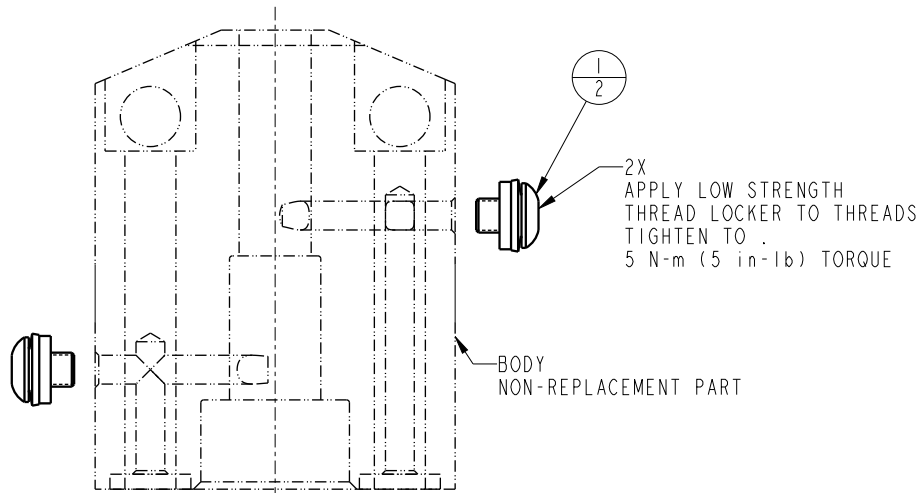

APPLY LOW STRENGTH
THREAD LOCKER TO THREADS
TIGHTEN TO
2.8 N-m (25 in-lb) TORQUE

NO	QTY	PART NO	DESCRIPTION	REPAIR KIT
1	2	21500055	SCREW, CAP, BTNH, M3 X 4, SST, w/ BND WSHER	X
2	1	23350133	SPRING, COMPRESSION	X
3	1	39051025	O-RING, (-011)	X
4	1	85040002	RETAINER, SENSOR, POSITION, PNEU	
5	1	85040004	PISTON, SENSOR, POSITION, PNEU, OC	
6	2	39V00053	O-RING, (-007)	X
9	N/A	P3037020	1/8 TUBE - M3 CONNECTOR	
N/A	N/A	62504000	KIT, REPAIR	NOTED
N/A	N/A	1S5003	INSTRUCTION SHEET	

PARTS LIST



VEKTEK, INC.
1334 E. SIXTH AVE. P.O. BOX 625
EMPORIA, KS. 66801 U.S.A.

ASSEMBLIES AFFECTED

45-0485-01

L5-0485-01

PARTS LIST, ASSY, SENSOR, POSITION, PNEU, OC

SIZE
A

MPL6904

REV
D

D	5164	RELEASE	RLK	8/28/23
REV	IN ACCORDANCE WITH ECN	EFFECTIVE DATE	REVISED BY	DATE
DRW BY:	MAJ	DRAWING STATUS: Released		
DATE:	11-11-16	PRODUCTION APPROVED FOR RELEASED STATUS ONLY		

FORM FEG035_PL_ASIZE, REV. B

SHEET 1 OF 2

THIS IS A TWO PAGE PARTS LIST.
 THIS SECOND PAGE APPLIES TO
 MODELS 45-0485-01 & L5-0485-01 AT REVISION A.

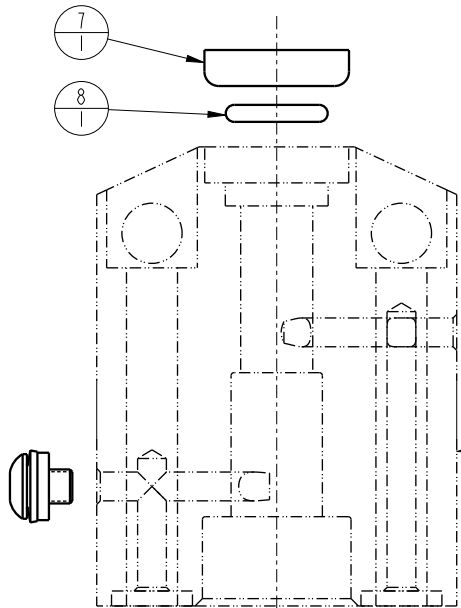

2X
 APPLY LOW STRENGTH
 THREAD LOCKER TO THREADS
 TIGHTEN TO .
 5 N-m (5 in-lb) TORQUE

BODY
 NON-REPLACEMENT PART

M3 FITTING IS AVAILABLE
 TO ORDER SEPERATELY
 AND NOT PROVIDED
 WITH THIS ASSEMBLY

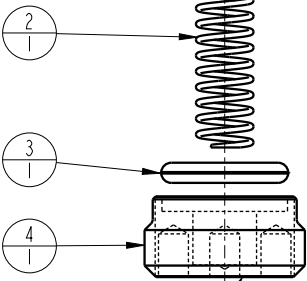
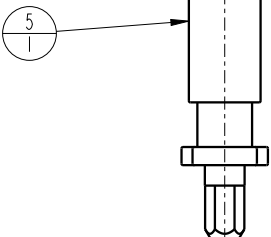
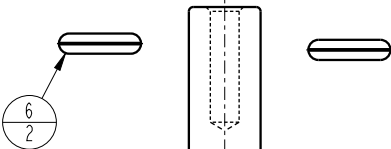

APPLY LOW STRENGTH
 THREAD LOCKER TO THREADS
 TIGHTEN TO
 2.8 N-m (25 in-lb) TORQUE

NO	QTY	PART NO	DESCRIPTION	REPAIR KIT
1	2	21500055	SCREW, CAP, BTNH, M3 X 4, SST, w/ BND WSHR	X
2	1	23350133	SPRING, COMPRESSION	X
3	1	39051025	O-RING, (-011)	X
4	1	85040002	RETAINER, SENSOR, POSITION, PNEU	
5	1	85040004	PISTON, SENSOR, POSITION, PNEU, OC	
6	2	39V00053	O-RING, (-007)	X
7	1	39V10029	WIPER, PRESS-IN, (1/4)	X
8	1	39V51001	O-RING, (6mm x 1.5)	X
10	N/A	P303720	1/8 TUBE - M3 CONNECTOR	
N/A	N/A	62504000	KIT, REPAIR	NOTED
N/A	N/A	IS5003	INSTRUCTION SHEET	

PARTS LIST



VEKTEK, INC.
 1334 E. SIXTH AVE. P.O. BOX 625
 EMPORIA, KS. 66801 U.S.A.

ASSEMBLIES AFFECTED
 45-0485-01
 L5-0485-01

PARTS LIST, ASSY, SENSOR, POSITION, PNEU, OC

SIZE
 A MPL6904

REV
 D

D	5164	RELEASE	RLK	8/28/23
REV	IN ACCORDANCE WITH ECN	EFFECTIVE DATE	REVISED BY	DATE
DRW BY:	MAJ	DRAWING STATUS: Released		
DATE:	11/11/16	PRODUCTION APPROVED FOR RELEASED STATUS ONLY		